



FA-165EX 04 ZONE 1 RED LED HELIDECK STATUS LIGHT REPEATER

The FA-165EX is an LED based Low Intensity Red Helideck Status Light Repeater designed for extreme environments such as high UV and marine conditions encountered on offshore oil and gas production facilities, drilling rigs and refineries.

Designed to be placed in remote locations, the lantern incorporates very long lived LEDs to minimize scheduled maintenance. The FA-165EX LEDs are mounted on metal core PCBs with patented integrated heat pipes to cool the LED arrays without a cooling fan. This highly efficient, passive, cooling system gives the LED array the highest design life in the marketplace (greater than 60,000 hours).



About this Lantern

FA-165EX 04: 5 Watt Red LED array providing the required candela for repeaters for helideck status lights conforming to CAP 437 requirements.



Features

- Two options for electronic controllers:
 - 100-240 ± 10% VAC 50-60 Hz internal controller
 - 20-30 VDC Helideck Status Light Controller, which can be remotely located up to 500 meters away
- 40W maximum internal power dissipation
- Integrated heat pipe eliminates need for cooling fan
- No moving parts
- Cover is tempered toughed glass, able to withstand high temperature and impact
- Base is impregnated, anodized and painted cast marine grade aluminum
- Stainless steel hardware
- Four 7mm diameter mounting holes. 229 mm (9") x 191 mm (7 17/32")

SPECIFICATIONS

**CORPORATE HEADQUARTERS
& MANUFACTURING
OPERATIONS**
Houston, TX
Phone: +1-713-228-5208
Fax: +1-713-228-3717
sales@automaticpower.com

U.S. LOCATIONS

PMAPI GULF OF MEXICO
Gray, LA
Rene "Boogie" LeBlanc
Phone: +1-985-223-8700
Fax: +1-985-223-8710
rleblanc@automaticpower.com

PMAPI WEST COAST
Novato, CA
Pete Dolan
Phone: +1-415-382-6296
Fax: +1-415-382-6299
pdolan@automaticpower.com

INTERNATIONAL LOCATIONS

AB PHAROS MARINE PTE LTD
Singapore
Phone: +65-6747-9325
Fax: +65-6746-0478
sales@pharos-api.com

**PHAROS MARINE LTD
MANUFACTURING OPERATIONS**
London, UK
Phone: +44-20-8538 1100
Fax: +44-20-8577 4170
sales@pharosmarine.com

**SIMS SYSTEMS LTD
MANUFACTURING OPERATIONS**
Great Yarmouth, UK
Phone: +44-1493 659271
Fax: +44-1493 601882
info@simms-systems.com

www.automaticpower.com

Height:	150 mm (5.86")
Weight:	5 kg (12 lbs.)
Input Voltage:	100-240 VAC or 20-30 VDC
Power Consumption:	5W
Available Colors:	Red
Quiescent Current:	14mA
Lens Type:	Tempered Glass
Visibility:	Conforms to CAP 437 Requirements
Vertical Divergence:	0° to 90°
Monitor and Control:	Located in Status Light Controller
Synchronization:	Cabling
Lantern Housing:	Epoxy Coated Cast Marine Grade Aluminum Base
Operating Temperature:	-20°C to +55°C (-40°C Optional)
Ingress Rating:	IP-66
Certificates:	<p>EC-Type Examination Certification Certificate No.: ITS10ATEX17055X Coding: II 2 G Ex d IIB T5 Tamb -20°C to +55°C Gb Optional: Tamb -40°C to +55°C Gb</p> <p>Certificate No.: IECEx ITS 10.0041X Coding: Ex d IIB T5 Tamb -40°C/-20°C to +55°C Gb (Dependent on Model)</p>

*Specifications subject to change without notice.

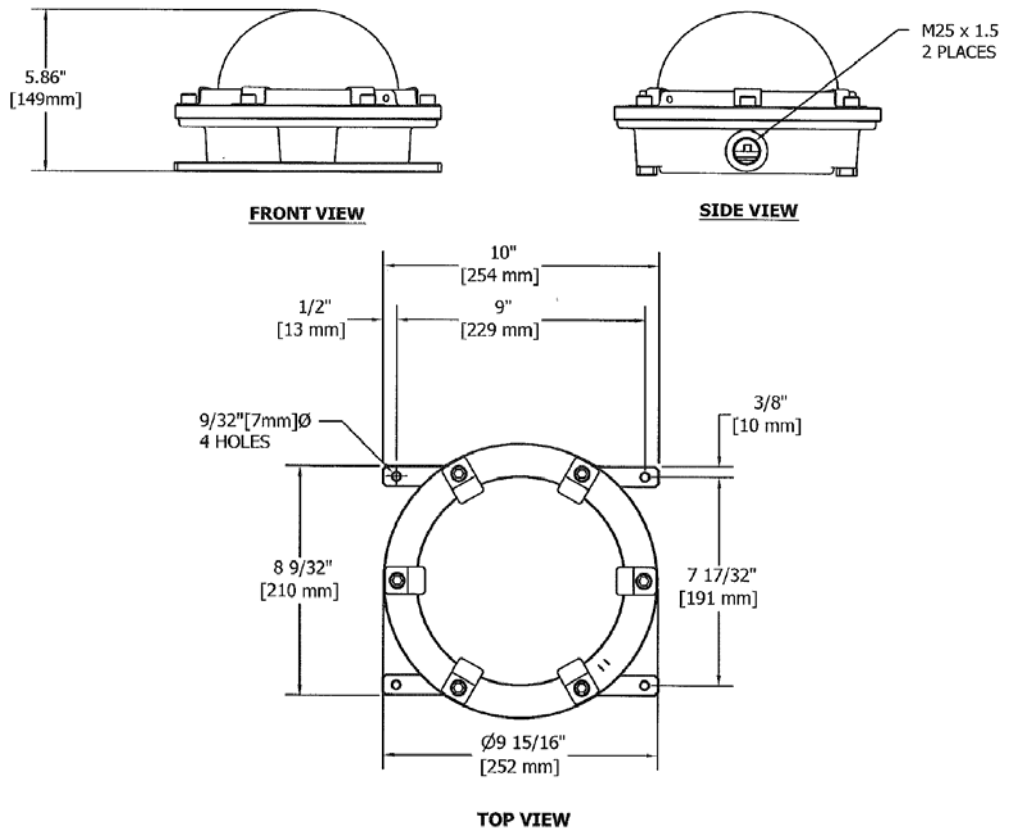

ORDERING REQUIREMENTS

The following ordering matrix is designed to assist you in the selection of the correct unit for your application. Build up the reference number by inserting the code for each component into the appropriate box.

FA-165EX Repeater Light:

Model	Led Assembly	Voltage/ Electronics	Temperature	Photocell						
165EX	1R	2D	<input type="text"/>	A1						
			<table><thead><tr><th><u>Temp</u></th><th><u>Code</u></th></tr></thead><tbody><tr><td>-20°C</td><td>4</td></tr><tr><td>-40°C</td><td>6</td></tr></tbody></table>	<u>Temp</u>	<u>Code</u>	-20°C	4	-40°C	6	None
<u>Temp</u>	<u>Code</u>									
-20°C	4									
-40°C	6									

Contact PMAPI Sales office for unique requirements.