

Mann
Tek

DDCouplings®

Kill the spill

STANAG 3756



When your product is:

- Expensive
- Expensive to clean up
- Expensive to reprocess or dispose
- Hazardous to workers or the environment
- Prone to accidental spillage and product loss

Use Mann Dry Disconnect Couplings for connecting and disconnecting hoses and pipelines quickly and without spillage



Benefits

- **Easy to handle:** push and turn - free flow, turn and pull - closed.
- **Time saving:** no need to drain hoses or pipe systems.
- **Economical:** No loss or spillage of liquids at connection or disconnection
- **Safety:** The valve cannot be opened until the unit is coupled.
- **Environmentally:** Accidental spillage eliminated.
- **Safety and reliability:** Due to the rugged construction.
- **Selectivity:** optional selectivity for preventing contamination due to incorrect and cross-coupling.
- **Product life:** Low number of moving parts, uncomplicated design and high quality materials ensures longer product life.

How it works

The principle of operation is identical for all sizes of couplings



Closed

Turn and pull - it's released
- *no spillage*

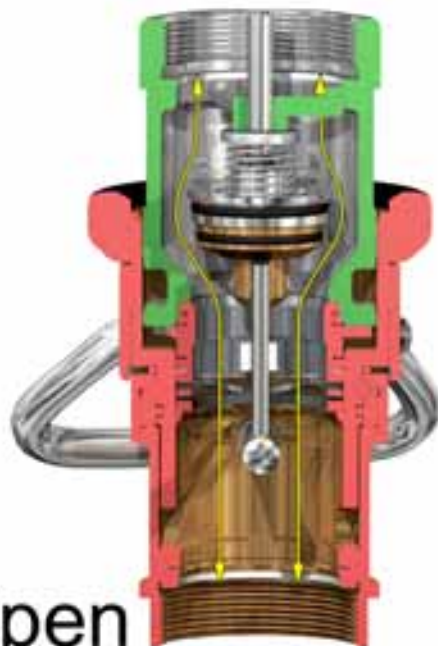

Open

Push and turn - it's coupled
- *full flow*

Advantages Stainless Steel Version

The Stainless Steel construction, has all moving parts pivoted in selflubricated bearings, the coupling function has been optimized for non-lubricating medias.

Our DDCoupling in Stainless Steel gives you the most positive, seal safe connections you can find anywhere.

The Tank unit is supplied with parallel BSP threads and flat sealing surface. This allows the use of the full thread length for screwed-on parts. Also available with flange, tapered internal NPT threads and parallel S60X6 threads.

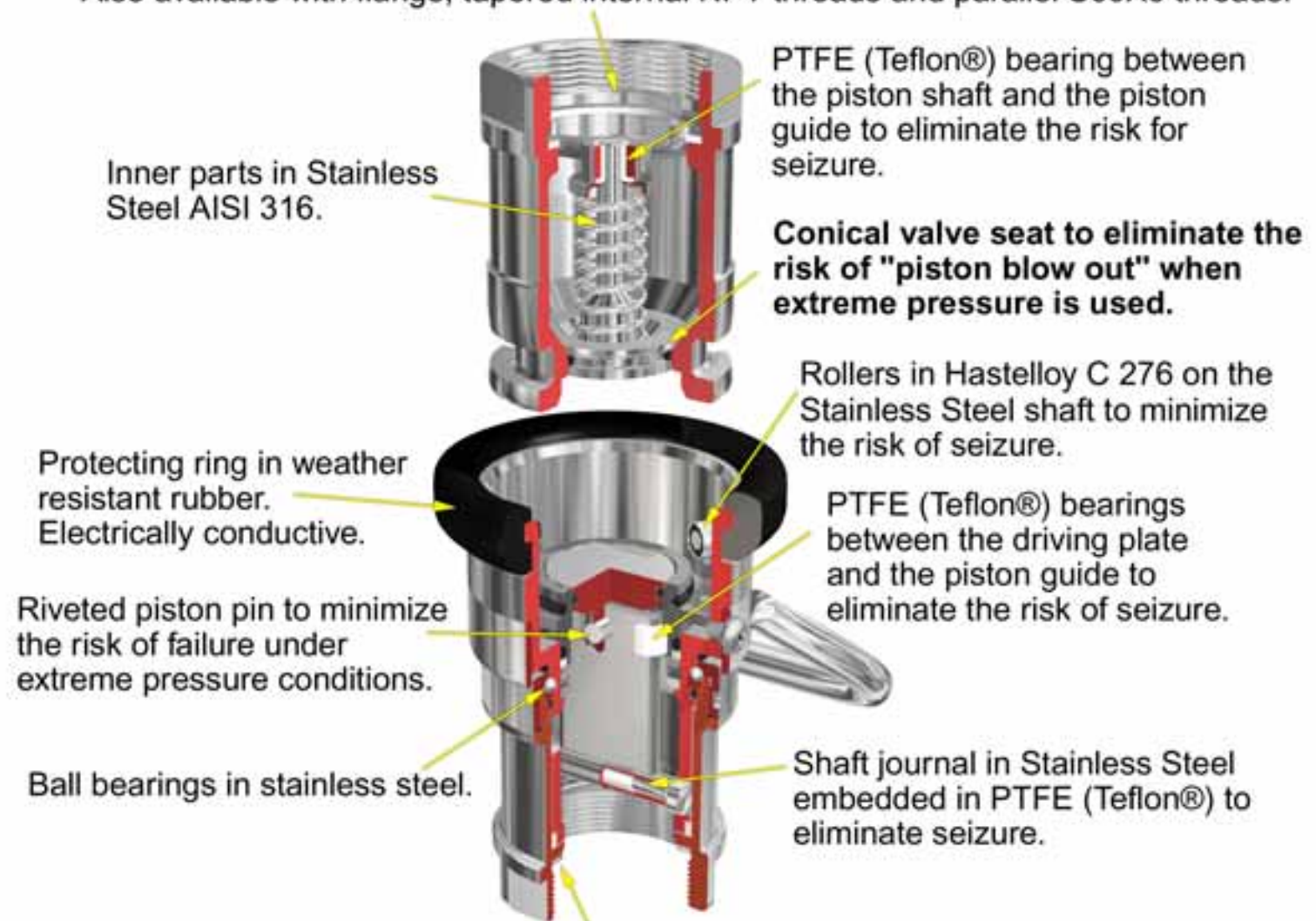

The Tank unit is supplied with parallel BSP threads and flat sealing surface. This allows the use of the full thread length for screwed-on parts. Also available with flange, tapered internal NPT threads and parallel S60X6 threads.

Standards

The DDCouplings are produced according to NATO Standard STANAG 3756 and ATOFINA SGM 2049.TUY.C.

Compatible with other existing brands.

DDCoupling product line

1" DDCouplings (Socket 56 mm):

Used in a diverse range of applications from Pharmaceutical processing to Auto gas vehicle fueling, perfume dosing to freon gas transfer.



2" DDCouplings (Socket 70 mm):

The 2" DDCoupling probably covers the widest selection of applications in the DDCoupling® range.

Ex: Diesel locomotive refueling,
Pharmaceutical processing,
Blending pits.



DDCoupling product line

2½" DDCouplings (Socket 105 mm):

Used extensively for road tanker bottom loading, aviation fuel bunkering (AVGAS), acid transfer, and lubrication oil blending.



3" DDCouplings (Socket 119 mm):

A true 3" coupling, similar in size to the 2 1/2" but with greater flow.

Typically used for road and rail tank loading/discharge, in plant chemical transfers etc.



DDCoupling product line

4" DDCouplings (Socket 164 mm):

Used extensively for offshore ship to rig transfers of fuels and drinking water, aviation fuel bunkering, rail tank loading/discharge etc.



Dustplugs and Dustcaps

Plugs and caps:

Available in Stainless Steel and Composite material.
Other material on request.



Special

Locking device:

To avoid unwanted disconnection.

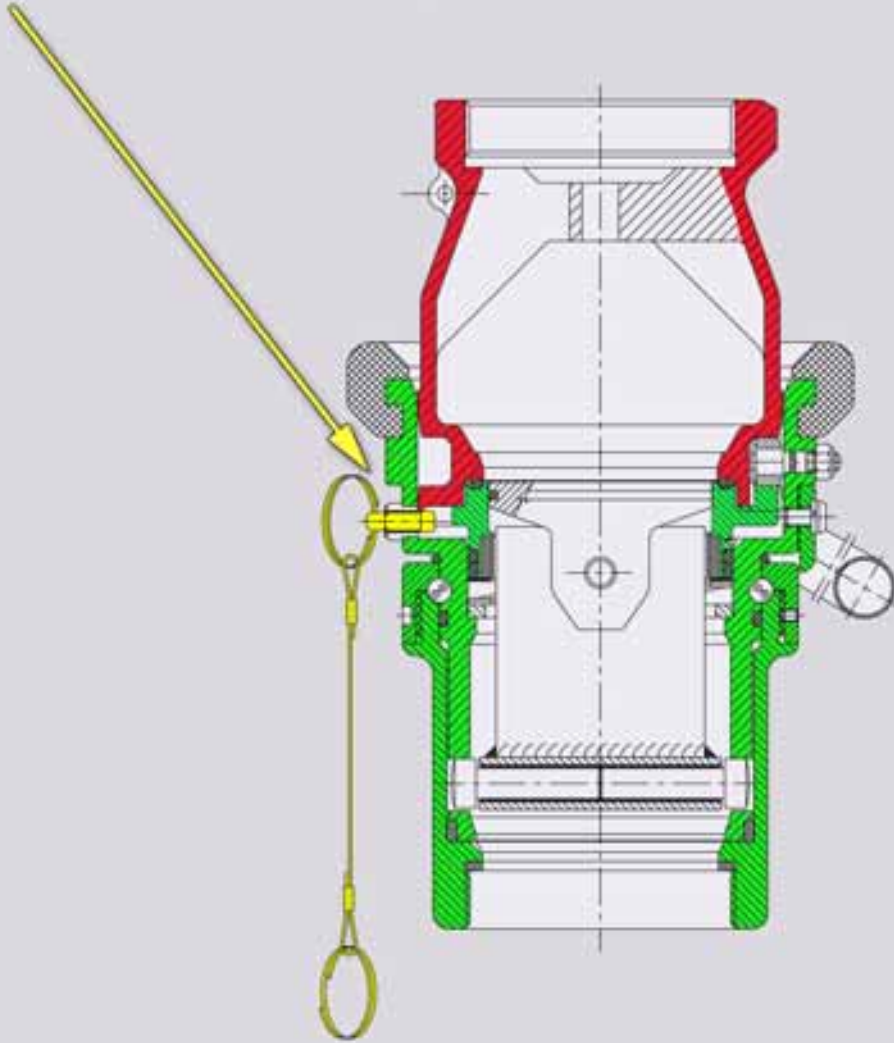

Special handle:

Customers request for special installations.

1" hose unit with handle



2" double handle

2 1/2" / 3" handle in Steel and Stainless Steel

Special

Transparent demo-version:

DDCouplings are available in a special transparent version, for demo purposes.



Non projecting piston spindle:

Tankunits with no parts projecting from the coupling in connected position. For mounting directly on ballvalves, etc.



Coupled

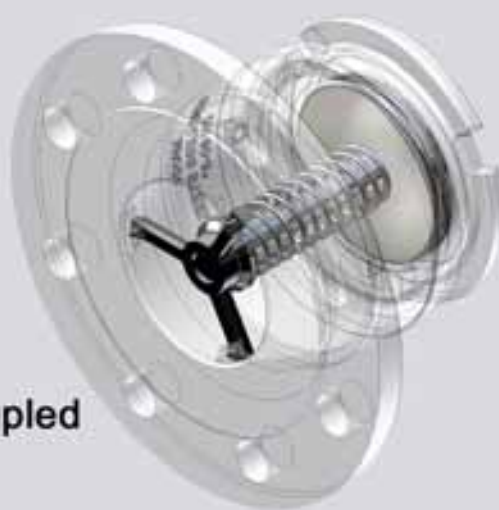

Uncoupled

Tank unit with excentric flange:

For drainage of pipe systems.



Special

Corrosive liquids:

DDCouplings are available in PEEK, a high resistant plastic material for corrosive liquids, or Hastelloy. Inner parts are of Hastelloy, seals of FPM, FFPM, CHEMRAZ® or Kalrez®.



PN 25 for gases:

DDCouplings in Stainless Steel have been approved and certified by APRAGAZ in pressure stage PN 25 bar for gaseous media, e.g. LPG, ethylene oxide and propylene oxide. Tank unit with a thick flange.
EN 1092-1:2001 Type E:Spigot.

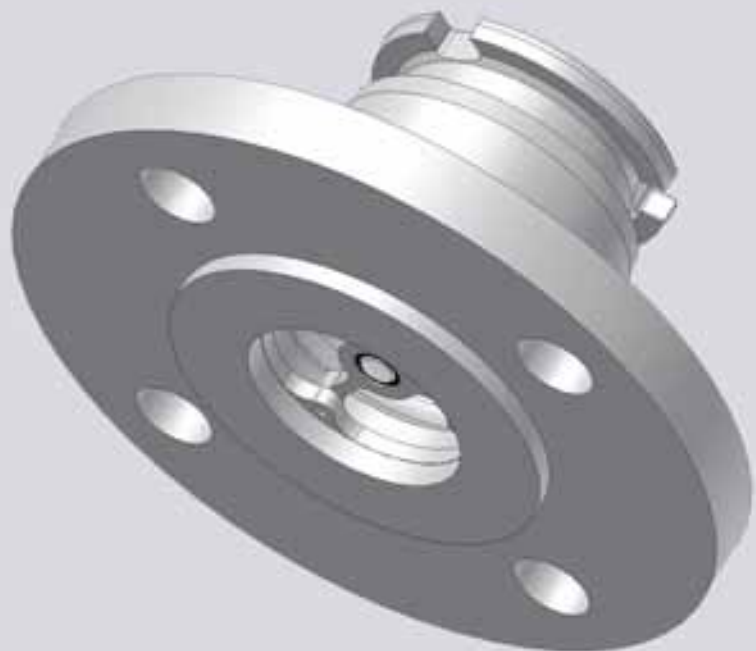

Special

High safety:

DDCouplings with integrated breakaway.
(Cable and bolt series).



Military applications:

DDCouplings correspond to NATO standard STANAG 3756, and are marked accordingly. The couplings are used by armed forces e.g. for tank refuelling in the field. On request they can be supplied with an olive-green varnish.



Hose unit with flange:

For installation on loading arms.



Special

Tank unit with pressure relief valve:

The tank unit with integrated pressure relief valve.

This system dissipates trapped fluid pressure into hose coupler without spillage, to allow easy connection.

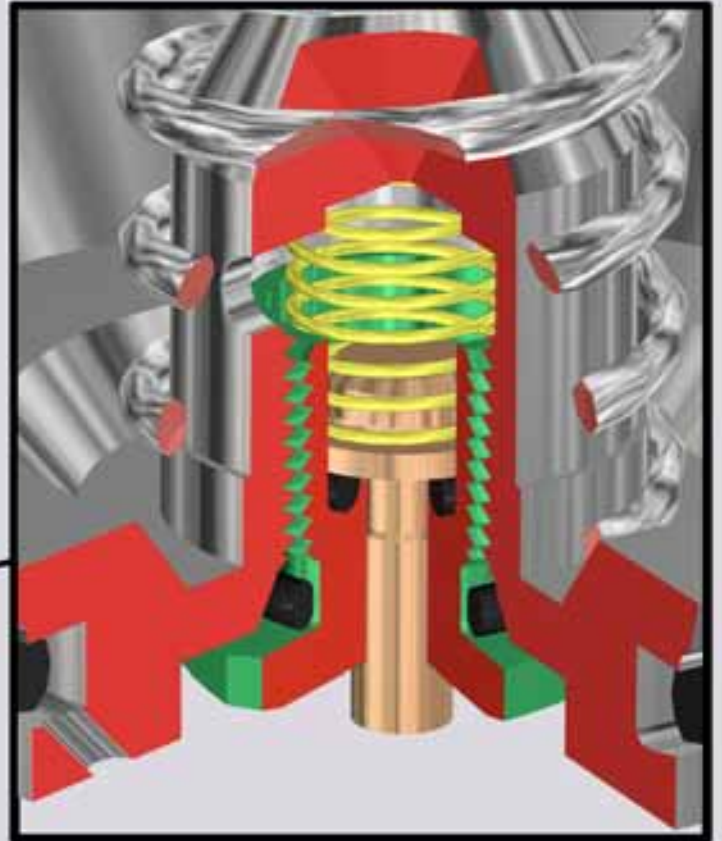
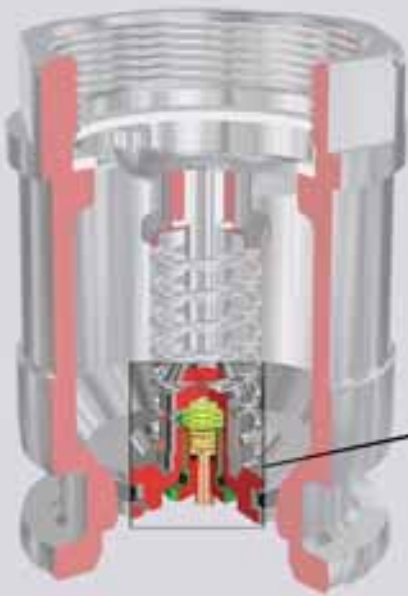

Coloured Handles

The DDCoupling handles can be in the following colours:
blue, green, yellow, red, black.



Applications - for DDCouplings



Applications - for DDCouplings



Flow diagram

Flow rate

Media: water.

Temp: 16° C.

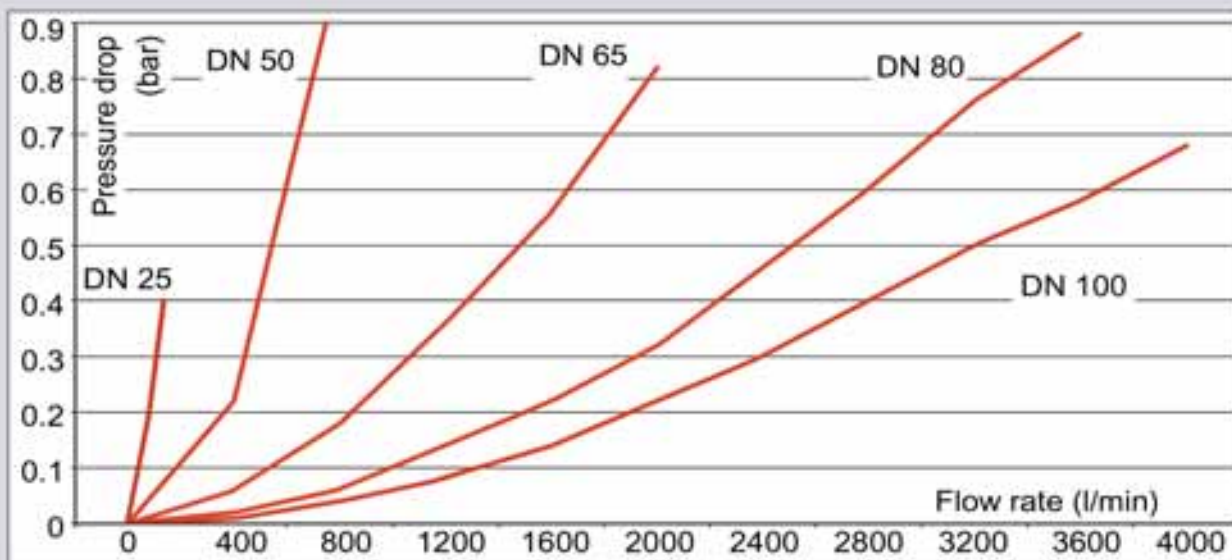

Selectivity

To avoid product contamination caused by connecting a hose unit to the wrong tank unit, selective versions of the hose and the tank units are available.

Each unit has a number of selective positions, designated by a coded part number according to the coupling size.

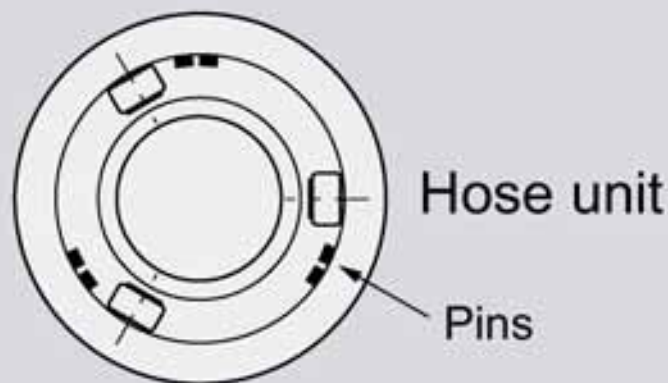
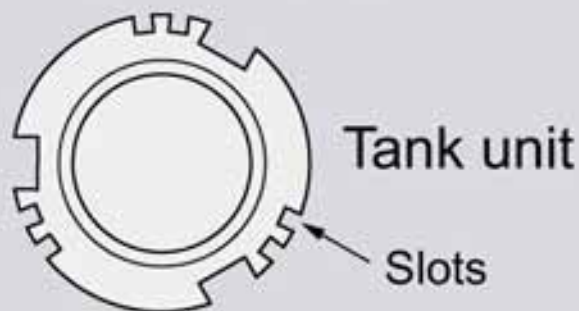

Selection of applications

Chemical & Oil:

- Bulk / loading / discharge
- Tanker top / bottom loading
- Loading arms
- Exchange manifolds
- Blending pits
- Bunkering
- Rail car outlets
- Rail shore side loading
- Paints & inks
- Improcess products transfer
- Rail locomotive refueling

Marine:

- Ship to ship transfer
- Ship to shore transfer
- Ship to rig transfer
- Rig gas exchange
- Rig temporary vent lines
- Ship manifold exchange
- Marine refueling

Specialized:

- Bulk powder transfer
- Natural gas
- Aviation bunkering
- Brewery finished product
- Food feedstock
- Pharmaceutical feedstock
- Hazardous waste transfer
- IBC container outlets
- Bitumen transfer
- ISO retrofit & new build

Approvals

TÜV, Veritas, Apragaz, TDT, etc.



Technical specification

Sizes: DN 20 - 3/4", to DN 100 - 4".
Connections: Thread BSP or NPT.
Flanges: DIN, ASA, TW, TTMA,
EN 1092-1:2001 Type E:Spigot.

Material: Aluminium, Brass/Gunmetall, Stainless Steel AISI 316,
Hastelloy and PEEK, other on request.
Sealing material: Standard FPM (Viton®), EPDM, HNBR, NBR (Nitril), Kalrez®,
CHEMRAZ®, and FFPM, other on request.
Flat seal for female BSP-threads: PUR / Polyurethan or PTFE (Teflon®).

Working pressure: Aluminium: PN 16,
Brass / Gunmetall: PN 25,
Stainless Steel: PN 25.
Test pressure: WP + 50%.
Minimum burst pressure: safety factor 5:1.

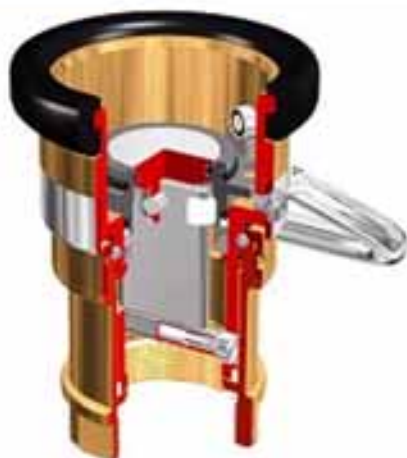

DDCoupling@

Dry Disconnect Coupling.
3/4" to 4", PN 16 - PN 25.
Material: Aluminium, Brass-Gunmetal,
Stainless Steel and PEEK.
Other materials on request.
According to NATO standard
STANAG 3756.



Break away, breaking pins

Aluminium, Brass, Stainless Steel, PN 16.
1½" to 4", female threads,
with breaking pins.



Break away, cable release

Stainless Steel, PN25.
1½" to 4", female threads.
6" to 8", flanged connection.



Swivel joints

3/4" to 4", PN 10 - PN 25.
Materials: Aluminium, Brass-Gunmetall,
Stainless Steel.
Other materials on request.
Connection: BSP, NPT.



Full Flow - Ballvalves

2" to 4", PN 10, Aluminium.
Ballvalve and 2-way Ballvalve.
Made for Petroleum Tank Trucks.
Variations of flange connections.