

**Mann**  
Tek

**SBCouplings**  
*Safety Break-away Couplings*

*Breaking Bolt series*  
*Industrial version*



**Safety first!**

- Driveaway incident protection for hose connections
- Safety for workers and environment

Art. nr: PR-010301-0121 Version 040506



### General info

For safe transfer of all your hazardous and non-hazardous products.

The Break-away Bolt release series, is designed specifically to minimize spillage and damage associated with drive away **and** pull away incidents.

The Coupling automatically senses an excessive load, closes its valves and then permits disconnection.



### How it works



The safety break-away valve consists of two halves, each with a valve that has a flat type-sealing surface similar to a dry disconnect coupling.

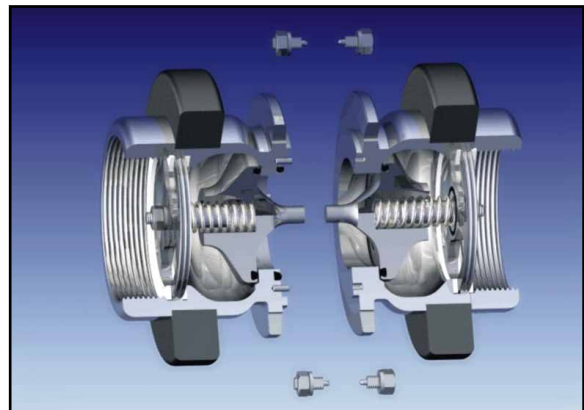

When the SBCouplings separate, it allows the poppets to close. The two poppets closes rapidly, minimizing exposure to personnel and the environment.

### Features

- Passive security against situations where a hose or loading arm could be subjected to inadvertent excessive loads.
- Design features are a simple mechanism and no loose components which could be lost after release.
- Operates independently of shut off safety system and does not require an external power source.
- Easy to reset on site with one person
- High flowrate / low pressure drop
- Very low loss, positive shut-off of both coupling halves results in minimum product loss.
- Lightweight and robust construction.
- Available with ANSI/DIN flanges or threaded (BSP or NPT).

## Range of applications

- Plant engineering and construction
- Power plant construction
- Chemical industry
- Food processing industry
- Process technology
- Tank cleaning
- Airfields
- Rail Cars
- Tanker Trucks
- Ship to Shore
- Ship to Rig
- Tank containers
- Any situation where a hose or a loading could be subjected to inadvertent excessive tensile loads.



## Versions of SBCouplings

**Industrial version** is utilized all industrial product transfer installations, the industrial SBCouplings is specifically designed to be able to activate with a tensile force being applied at an angle to the plane of the coupling housing, up to 90 degrees for bolt version, and 30 degrees for cable release version.

*Exists with both cable and bolt versions.*

**Marine version** of SBCouplings are designed specifically to be installed within a hose string, where the coupling would have a length of hose attached to both sides.

This coupling incorporates the same internal mechanism as our Industrial couplings, but has additional external features that provide increased resistance to torsional and bending moment forces which may be applied to the coupling, preventing premature activation in the unpredictable marine environment. Typical applications include ship to offshore platform, and ship to ship product transfer operations.

*Exists only in bolt version.*

**Non-Closure version** is available in both the Industrial and Marine versions of our couplings, the Non-Closure design acts purely as an identified safe parting point within the transfer system, protecting equipment and personnel.

With no internal mechanism these couplings are utilised when the medium is non-hazardous and spillage is acceptable.

*Exists only in bolt version.*

## Materials and WP

## Sizes

### Materials:

Stainless Steel AISI 316TI, other materials on request.

Orings: FPM (Viton®) other materials on request.

Flat seals in PTFE (Teflon®) other materials on request.

**Working pressure:** PN 25 (360 psi)

DN 40 / 1½" \*

DN 50 / 2"

DN 65 / 2½" \*

DN 80 / 3"

DN 100 / 4"

DN 150 / 6"

DN 200 / 8"

\*Only on request

## Approvals

Functionality testing approved by TÜV (Germany), etc.

Approved by Bundesamt für Materialforschung (BAM)(Germany)

Approval in accordance to §19 Wasserhaushaltsgesetz (WHG)(Germany)