

1 1/2 inch SELF SEALING INDUSTRIAL COUPLINGS



GENERAL INFORMATION

Avery-Hardoll self sealing couplings are designed for use wherever it is necessary to connect and disconnect hoses and pipelines under pressure, quickly and without spillage. They are designed primarily for use in the petroleum and chemical industries where reliability and safety are of prime concern.

OPERATION

Operation is single action, using a straightforward turning motion to connect the couplings and open a flow path.

An initial push and turn action on the hose unit causes engagement with the tank unit, thus locking and sealing the two units together. Further rotation causes the internal valves to open, thereby allowing flow with minimum pressure drop.

The connection and valve mechanism is interlocked such that the valve can only be opened by fully engaging and sealing the hose unit on its matching tank unit.

On disconnection, the valves fully close before the couplings separate and spillage is therefore negligible.

LOW COST

FAIL SAFE TANK UNITS

UNRIVALLED QUALITY FOR TROUBLE FREE OPERATION AND LONG LIFE

NEGLECTIBLE SPILLAGE

ENVIRONMENTALLY FRIENDLY

HOSE UNIT FITTED WITH SWIVEL AS STANDARD

EASY SINGLE ACTION COUPLING AND VALVE OPENING

MATERIAL: GUNMETAL

NITRILE OR FLUOROCARBON SEALS

SEVEN SELECTIVITY OPTIONS

1 - HOSE UNIT CCMY 6153N*

Material Gunmetal

Weight 2.2 kg (4.13 lb)

Max. Working Pressure 175 psi (12 bar)

Max. Coupling Pressure 60 psi (4 bar)

Test Pressure 265 psi (18 bar)

2 - As above,
Unit with Handle CCMY 6153NH

3 - TANK UNIT
FLANGED VERSION CCMY 6150N

Material Gunmetal

Weight 2.3 kg (5 lb)

Max. Working Pressure 175 psi (12 bar)

Test Pressure 265 psi (18 bar)

Flanged tank units are normally supplied undrilled, but can be drilled to customer requirements on request

4 - TANK UNIT
THREADED VERSION CCMY 6151N

Material Gunmetal

Weight 1.25 kg (2.75 lb)

Max. Working Pressure 175 psi (12 bar)

Test Pressure 265 psi (18 bar)

DUST CAP FOR
HOSE UNIT CCMY 324

Material Synthetic Rubber

Weight 0.2 kg (0.37 lb)

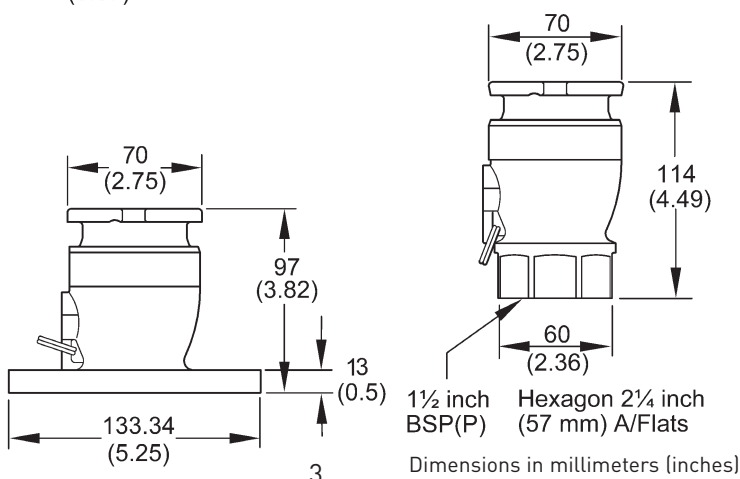
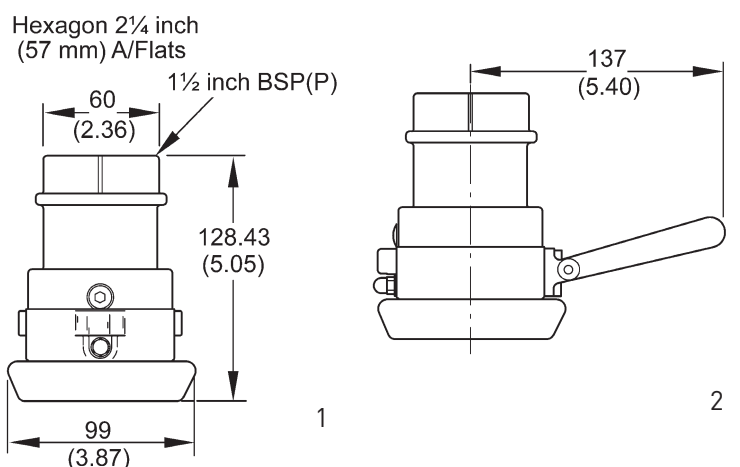

DUST CAP FOR
TANK UNIT CCMY 4SP1*

Material Aluminium Alloy

Weight 0.4 kg (0.87 lb)

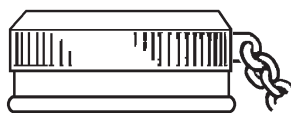

* Seals
Nitrile as standard
for Fluorocarbon change suffix to V

SELECTIVITY

To avoid product contamination caused by connecting a hose unit to the wrong tank unit, selective versions of the hose and tank units are available.

Selective Position Letter	T	U	V	W	X	Y	Z
Pin and Slot Position	as shown						

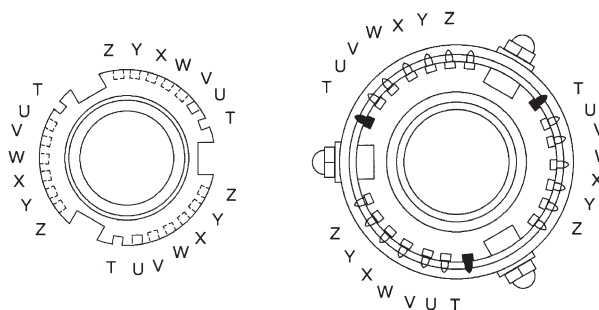

Eastern Petroleum Supplies Ltd
New House Farm, Maldon Road
Steeple. UK CM0 7RR

Tel + 44 (0) 1621 773292
Fax + 44 (0) 1621 772353
E-Mail info@easternsupplies.co.uk
Web www.easternsupplies.co.uk

MEGGITT